



VIVIENDA TIPO A



VIVIENDA TIPO B



SITUACIÓN



EMPLAZAMIENTO



SUPERFICIES DE PARCELAS	
SUPERFICIES EN M2	
PARCELA N° 1	152,60
PARCELA N° 2	153,80
PARCELA N° 3	145,65
PARCELA N° 4	143,65
PARCELA N° 5	136,70
PARCELA N° 6	155,75
PARCELA N° 7	151,75
PARCELA N° 8	243,25
PARCELA N° 9	238,45
PARCELA N° 10	228,60
PARCELA N° 11	215,70
PARCELA N° 12	266,30
ZONA PISCINA	556,05
CALLE INTERIOR	447,75
TOTAL:	3.236,00



MANZANA M-17
PLANO DE PARCELA 1/350

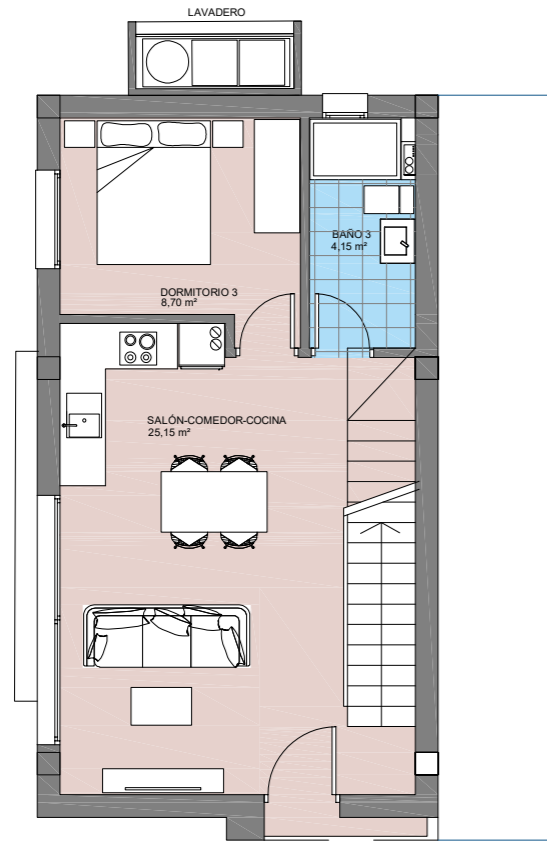

PLANTA BAJA

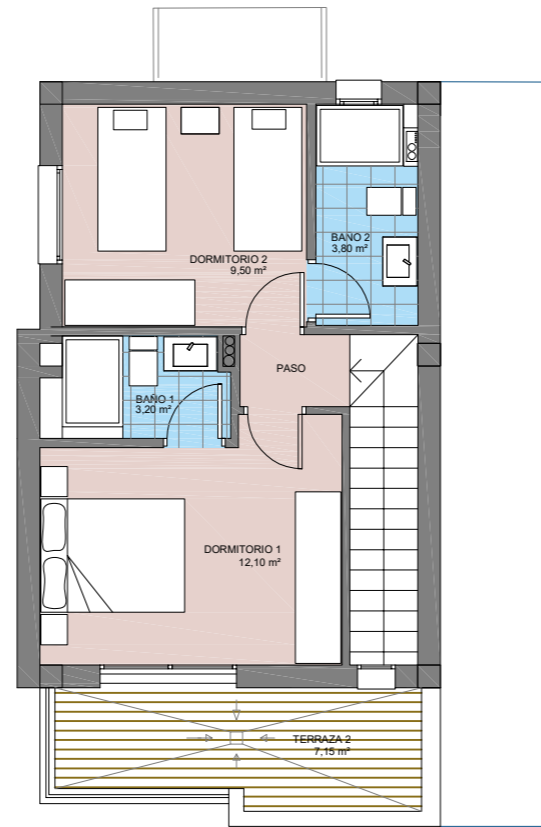

PLANTA PRIMERA

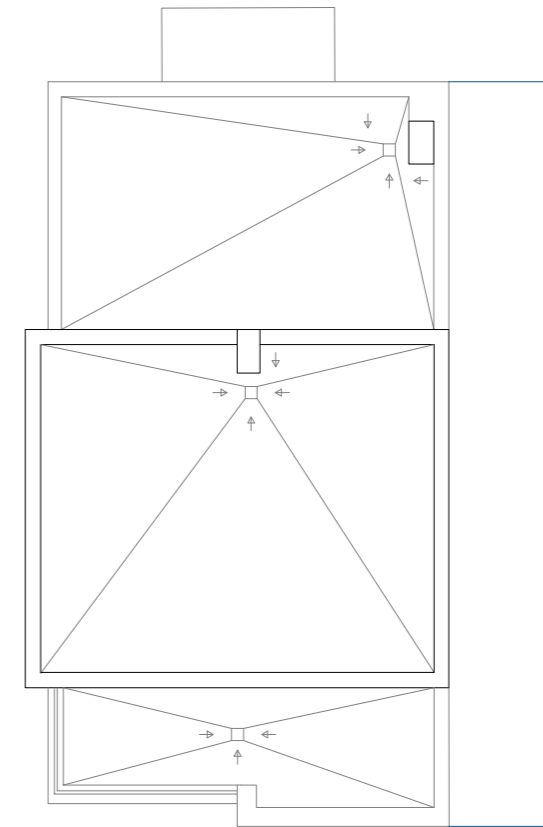

PLANTA CUBIERTA

DISTRIBUCIÓN VIVIENDA

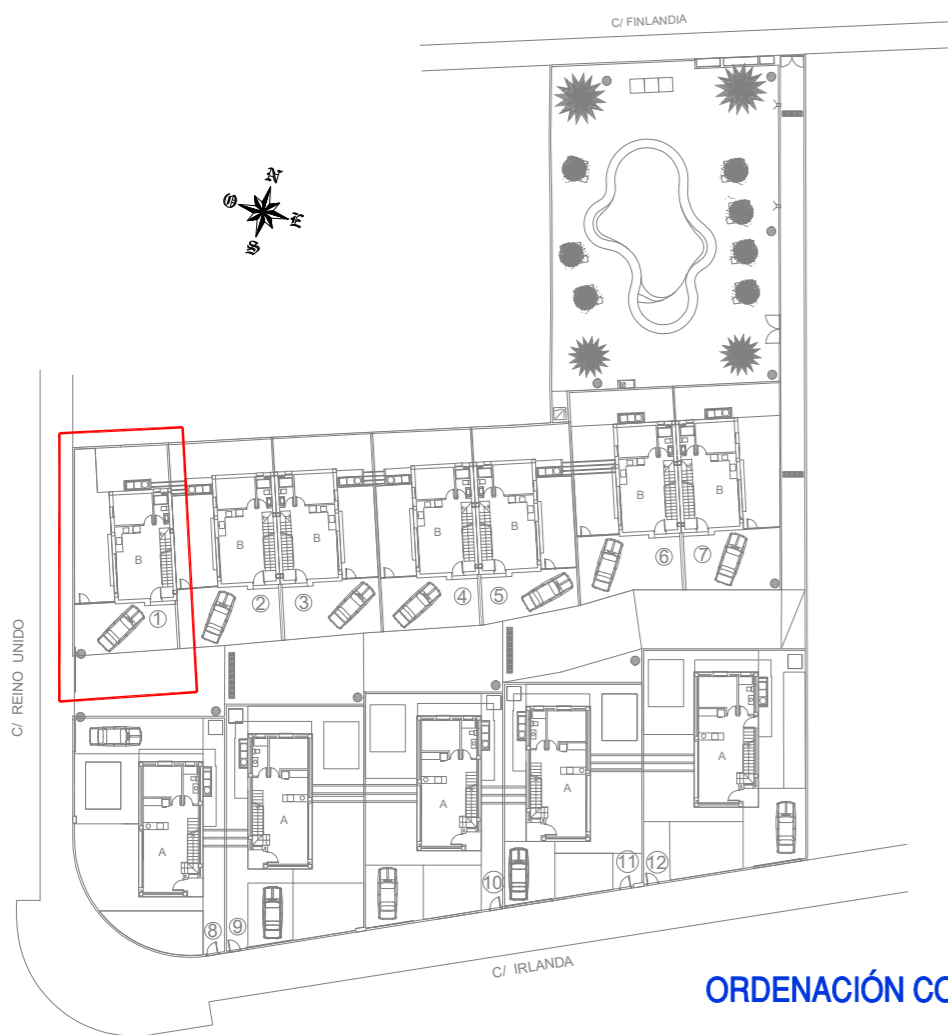

ORDENACIÓN CONJUNTO

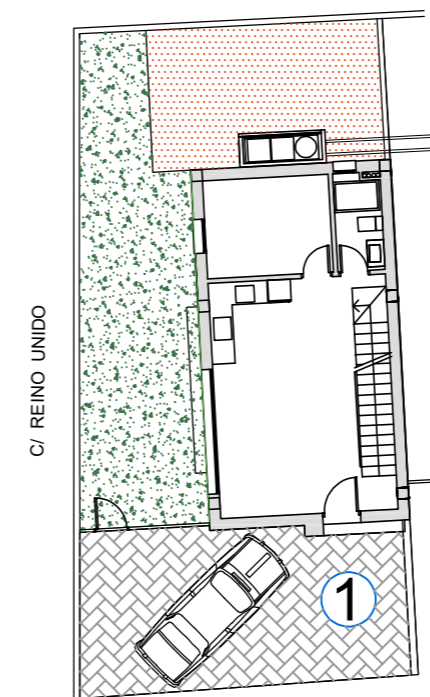

PLANO DE PARCELA

C/ Clavel Florentino, 134
03203 ELICHE (Alicante)
Telf.: 96 541 03 78
www.asagrupo.com

CUADRO DE SUPERFICIES		Manzana M17	
PARCELA 1 AGRUPADA			
TOTAL SUPERFICIE PARCELA 1		152,60m²	
VIVIENDA 4			
PLANTA BAJA	VIVIENDA	54,65m ²	54,65m ²
PLANTA ALTA	VIVIENDA	43,90m ²	43,90m ²
TOTAL SUPERFICIE VIVIENDA		98,55m²	
RESTO PARCELA - JARDIN - APARCAMIENTO		97,95m ²	

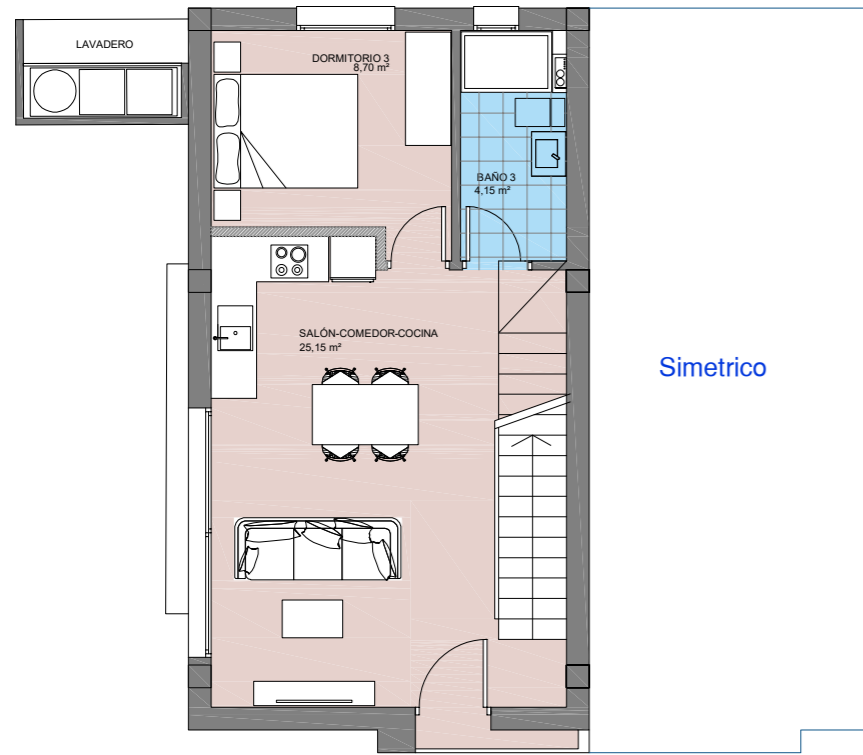

Simetrico

PLANTA BAJA

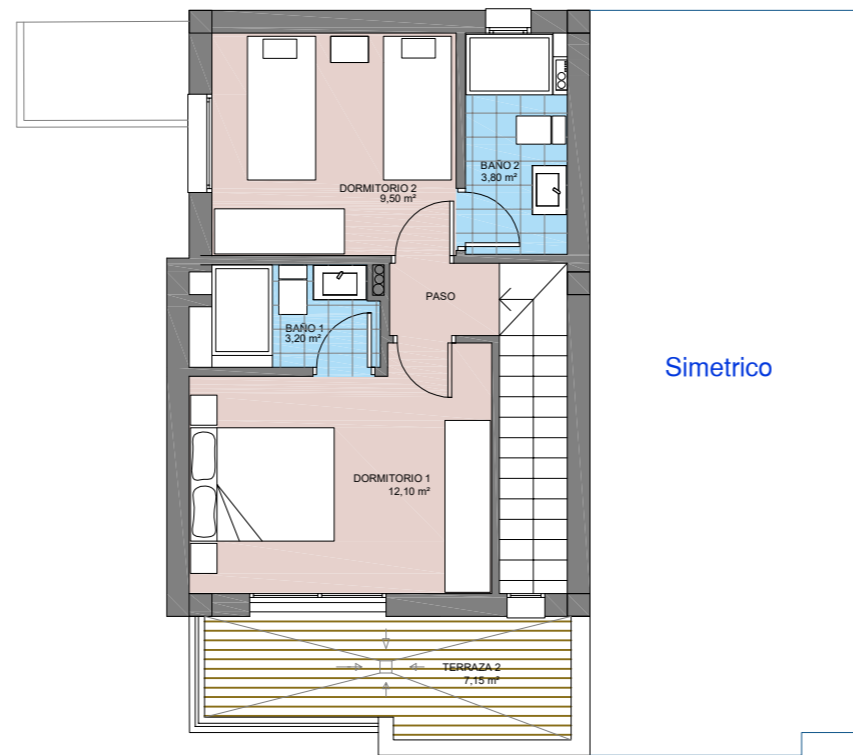

Simetrico

PLANTA PRIMERA

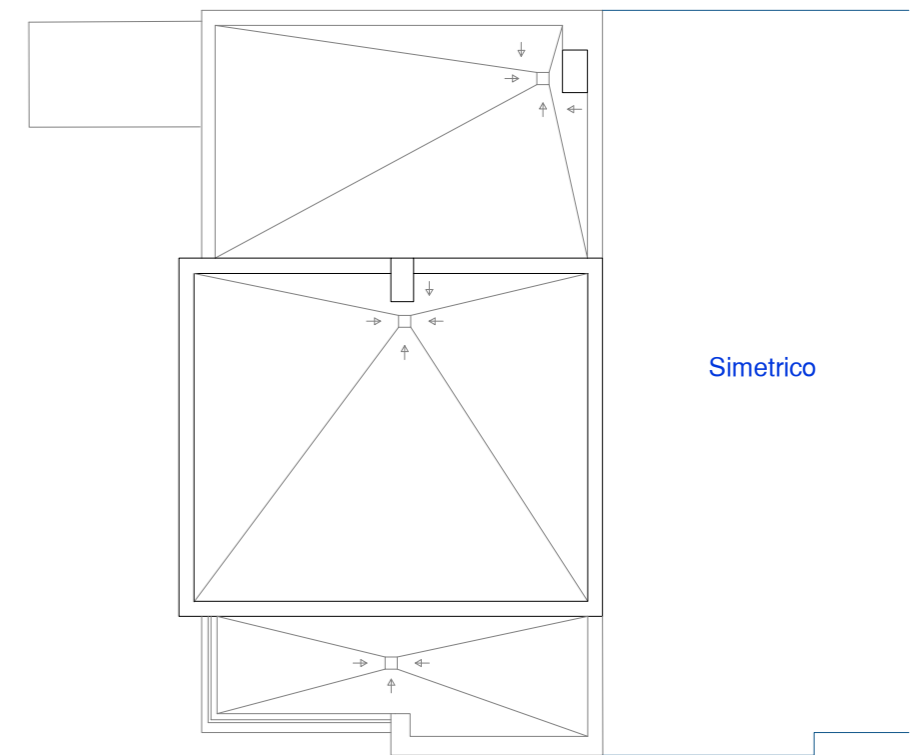

Simetrico

PLANTA CUBIERTA

DISTRIBUCIÓN VIVIENDA

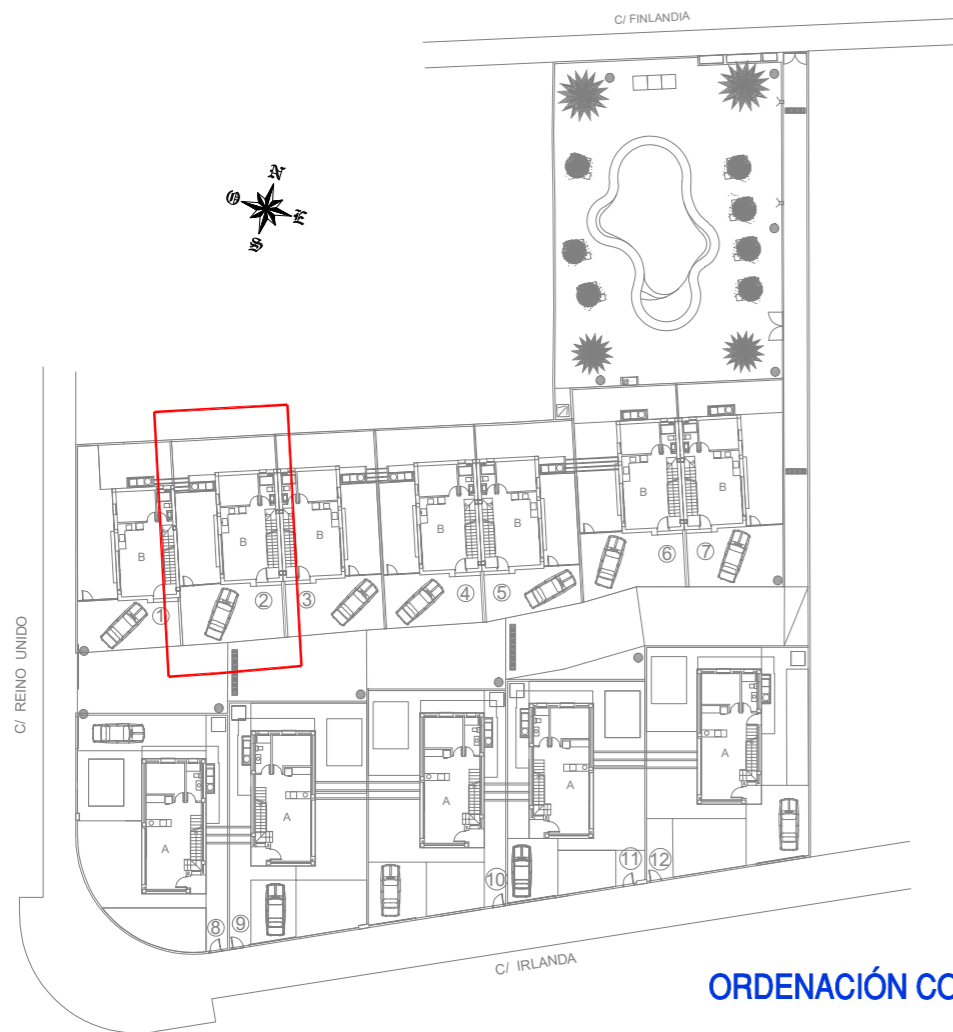

ORDENACIÓN CONJUNTO

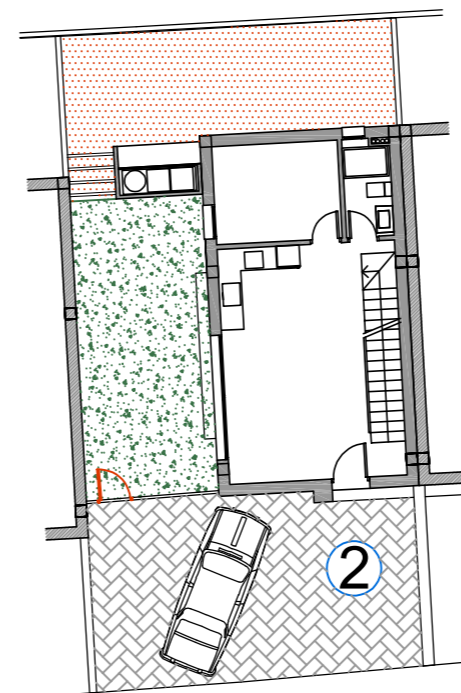

PLANO DE PARCELA

		C/ Clavel Florentino, 134 03203 EL CHE (Alicante) Telf: 96 541 03 78 www.asagupo.com	
CUADRO DE SUPERFICIES Manzana M17			
PARCELA 2 AGRUPADA			
TOTAL SUPERFICIE PARCELA 2			153,80m2
VIVIENDA 4			
PLANTA BAJA	VIVIENDA	54,65m2	54,65m2
PLANTA ALTA	VIVIENDA	43,90m2	
TOTAL SUPERFICIE VIVIENDA			98,55m2
RESTO PARCELA - JARDIN - APARCAMIENTO			99,15m2

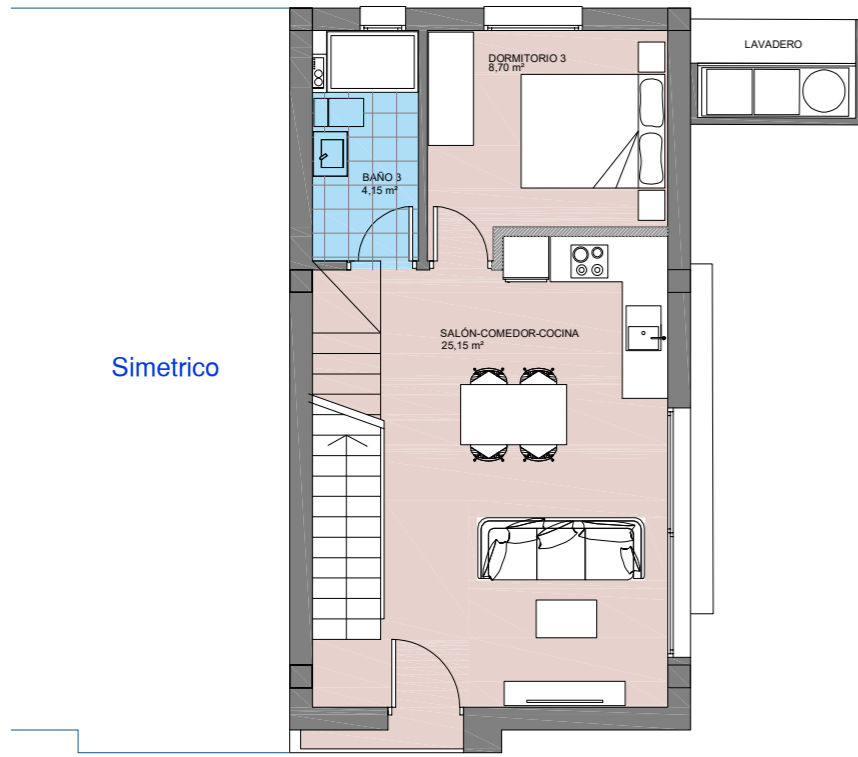

PLANTA BAJA

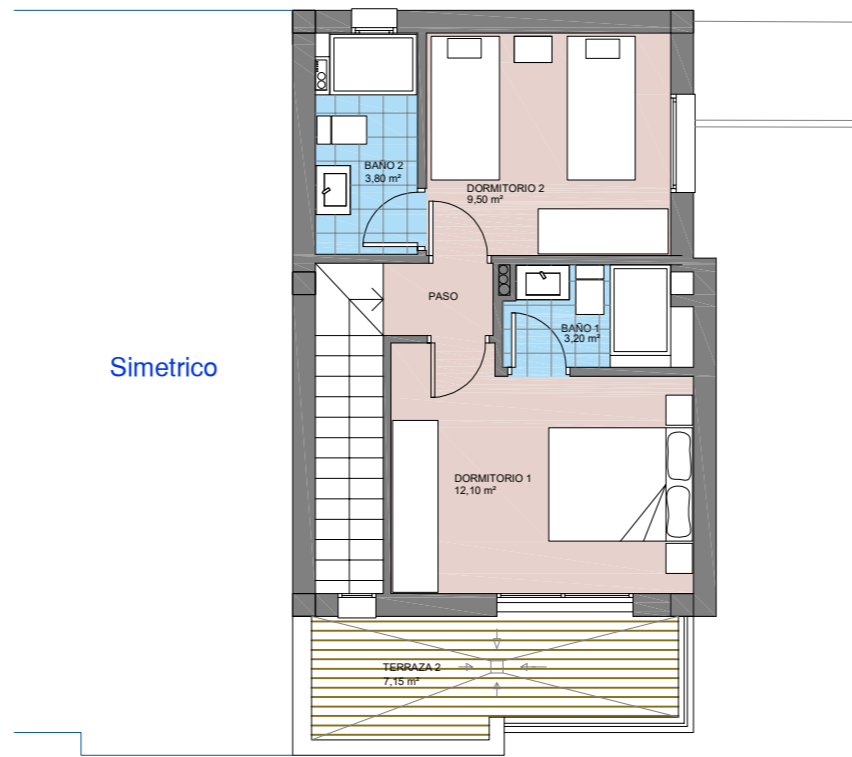

PLANTA PRIMERA

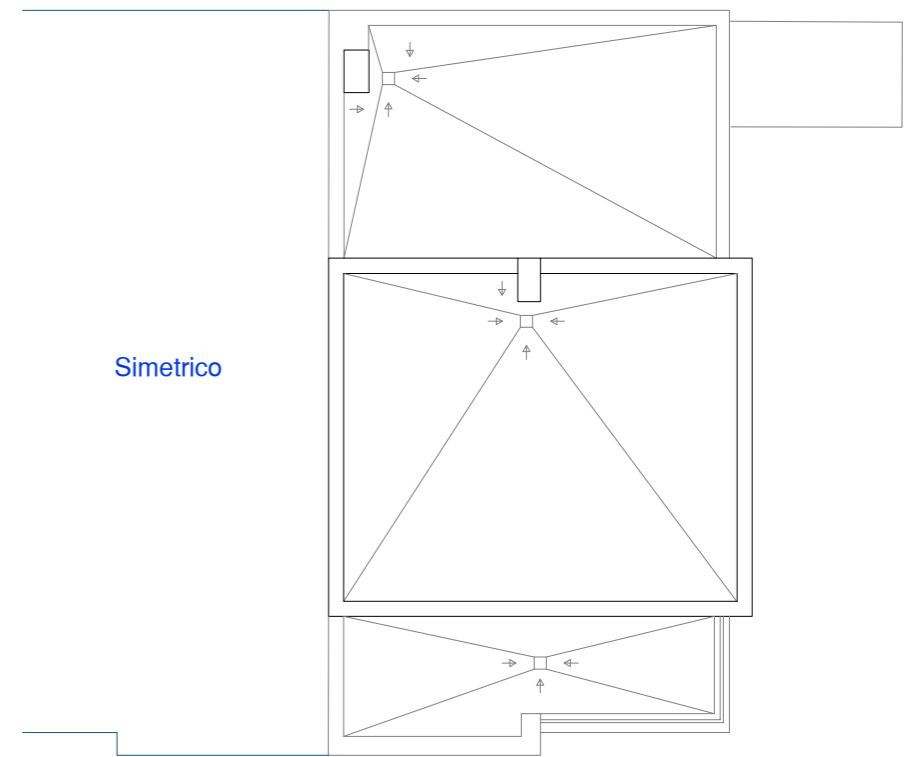

PLANTA CUBIERTA

DISTRIBUCIÓN VIVIENDA

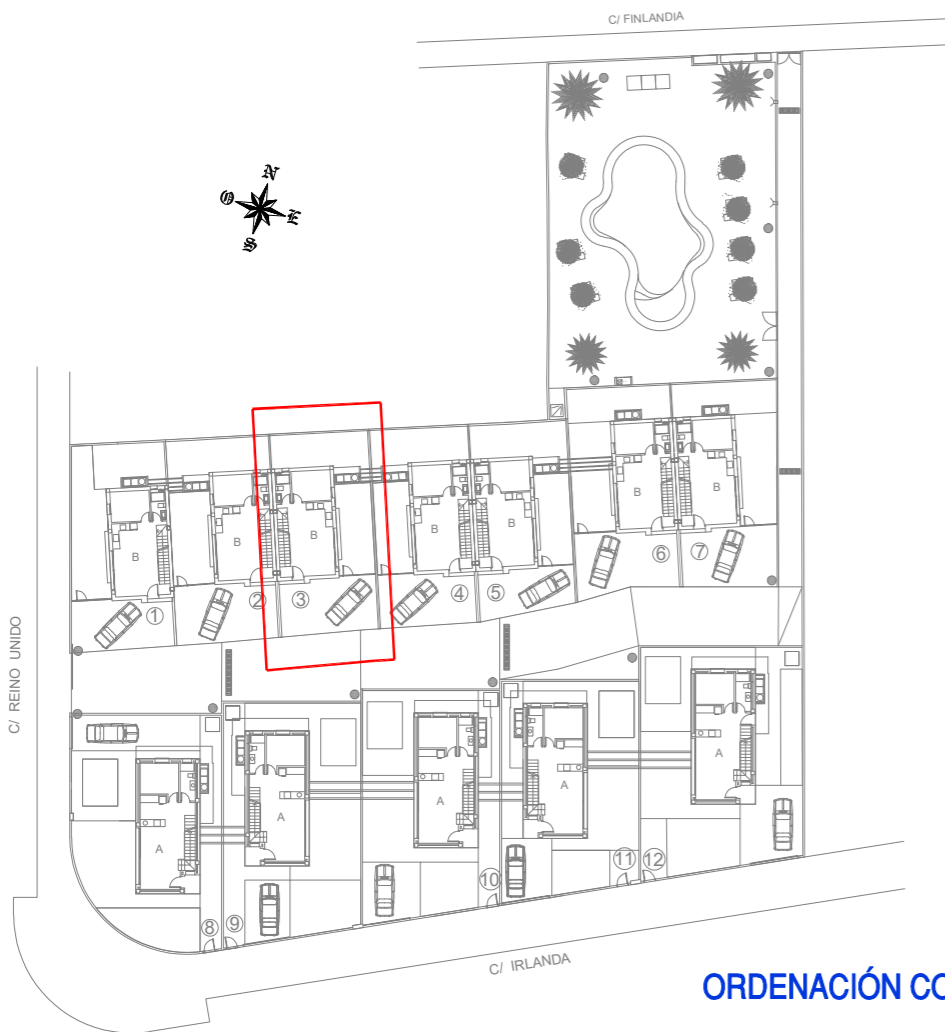

ORDENACIÓN CONJUNTO

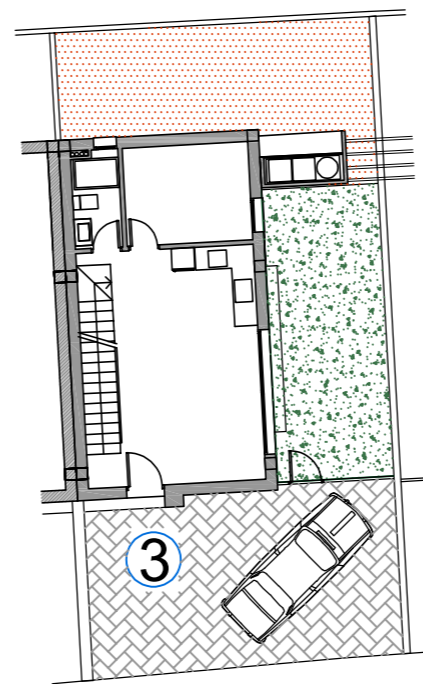

PLANO DE PARCELA

		C/ Clavel Florentino, 154 03203 ELICHE (Alicante) Telf.: 96 541 03 78 www.asagrupo.com	
CUADRO DE SUPERFICIES		Manzana M17	
PARCELA 3 AGRUPADA			
TOTAL SUPERFICIE PARCELA 3			145,65m2
VIVIENDA 4			
PLANTA BAJA	VIVIENDA	54,65m2	54,65m2
PLANTA ALTA	VIVIENDA	43,90m2	43,90m2
TOTAL SUPERFICIE VIVIENDA			98,55m2
RESTO PARCELA - JARDIN - APARCAMIENTO			91,00m2

Este documento tiene carácter informativo, reflejando información elaborada de estudios previos del proyecto, la cual puede sufrir modificaciones de carácter técnico-jurídicas derivadas de la redacción del Proyecto y de su ejecución. Todo el mobiliario que figura en la vivienda es meramente decorativo y no está incluido en el precio de la misma, excepto el mencionado en la memoria de calidades. La decoración, colorido y mobiliarios son figurados y no vinculantes.

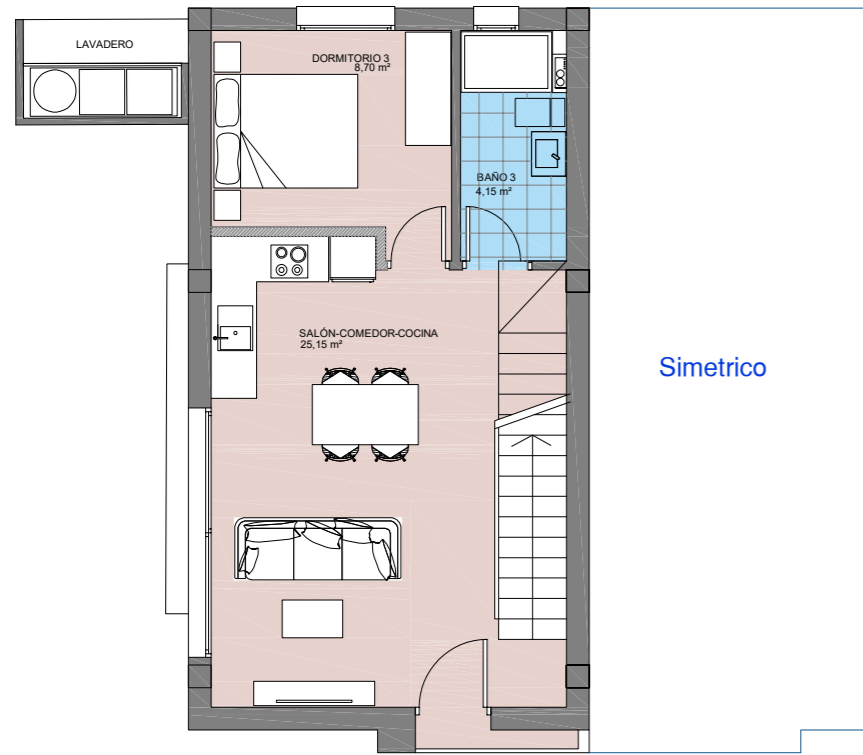

Simetrico

PLANTA BAJA

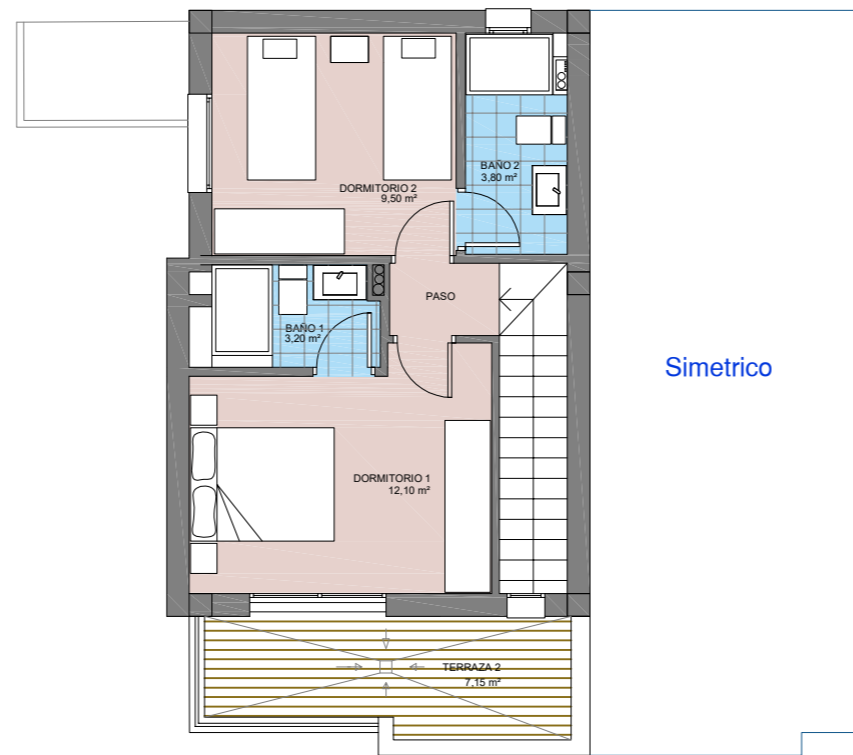

Simetrico

PLANTA PRIMERA

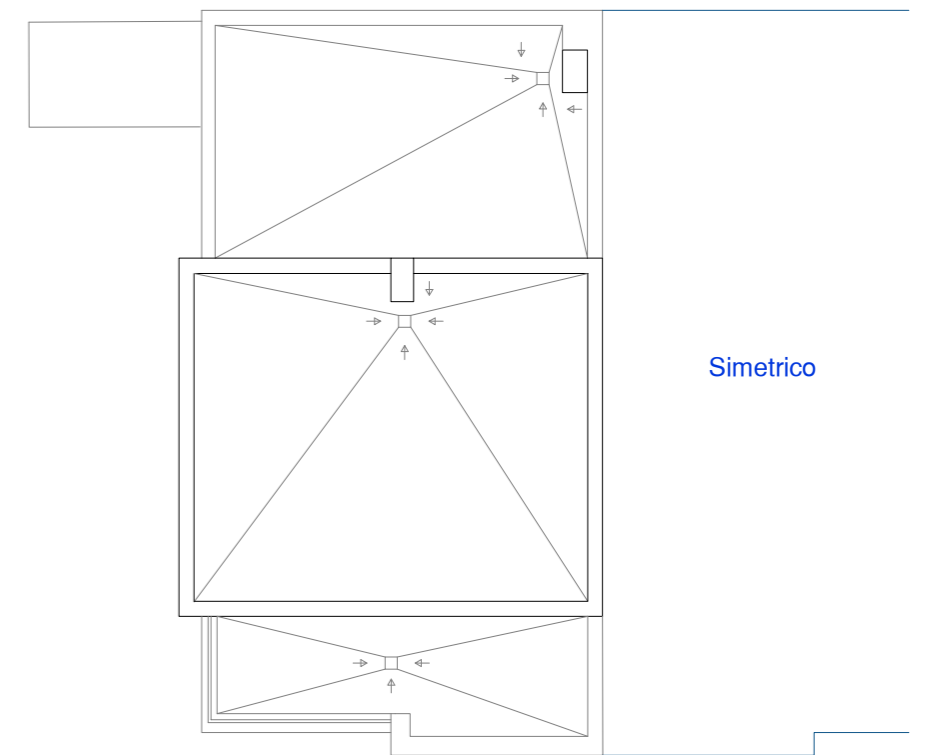

Simetrico

PLANTA CUBIERTA

DISTRIBUCIÓN VIVIENDA

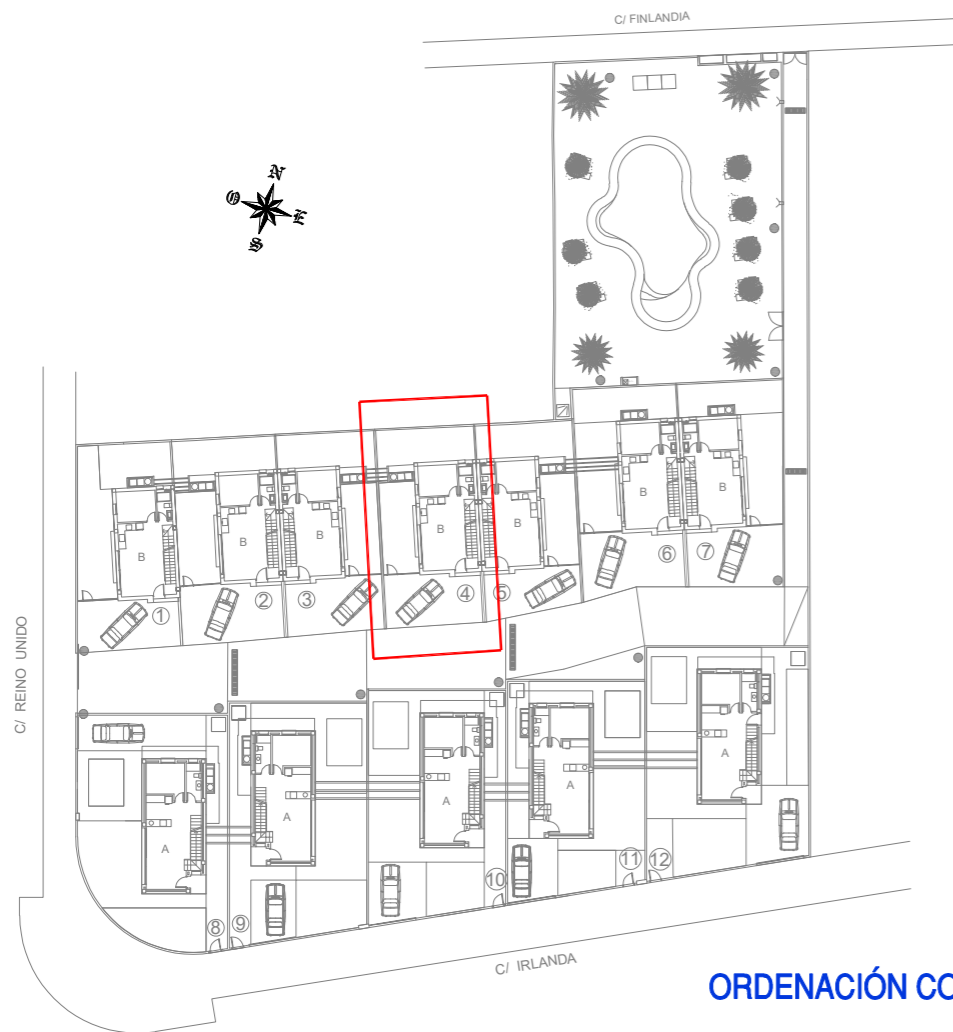

ORDENACIÓN CONJUNTO

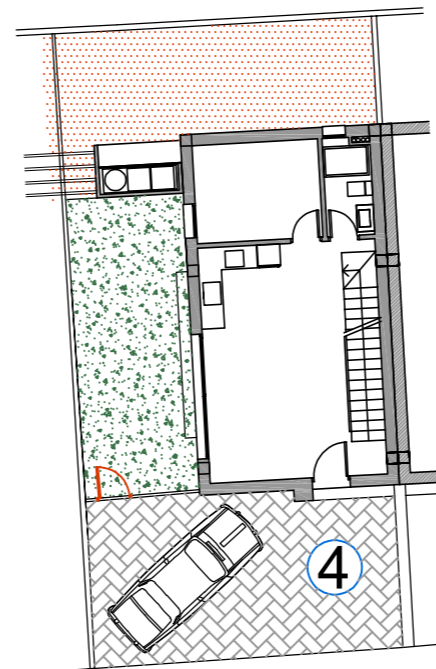

PLANO DE PARCELA



C/ Clavel Florentino, 134
03203 EL CHE (Alicante)
Telf: 96 541.03 78
www.asagrup.com



NATURA PINET
RESIDENCIAL LA MARINA

CUADRO DE SUPERFICIES **Manzana M17**

PARCELA 4 AGRUPADA		TOTAL SUPERFICIE PARCELA 4	
		143,65m2	
VIVIENDA 4			
PLANTA BAJA	VIVIENDA	54,65m2	54,65m2
PLANTA ALTA	VIVIENDA	43,90m2	43,90m2
TOTAL SUPERFICIE VIVIENDA		98,55m2	
RESTO PARCELA - JARDIN - APARCAMIENTO		89,00m2	

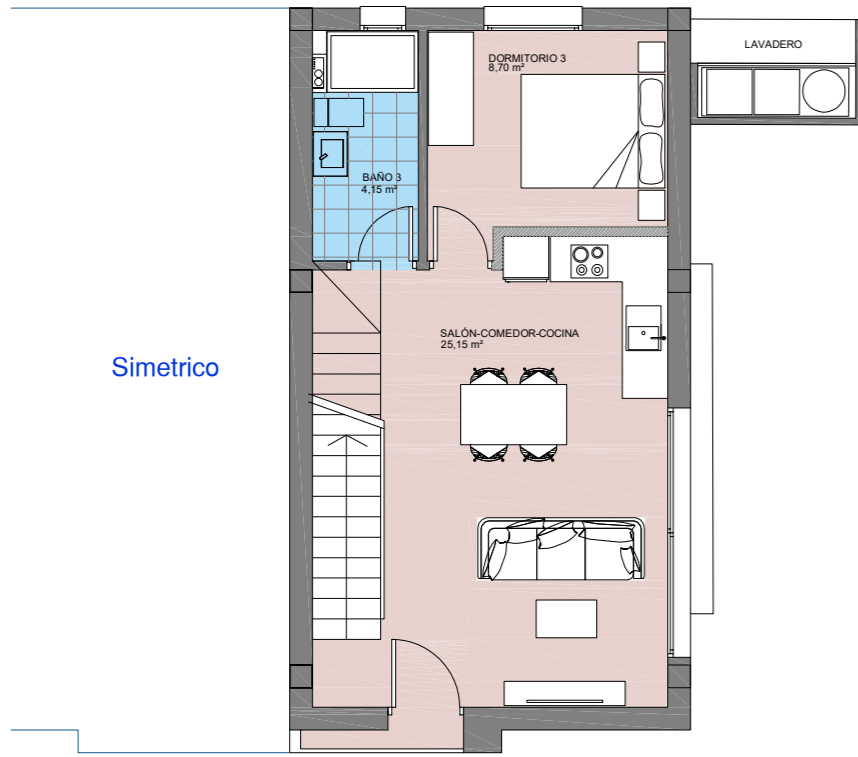

PLANTA BAJA

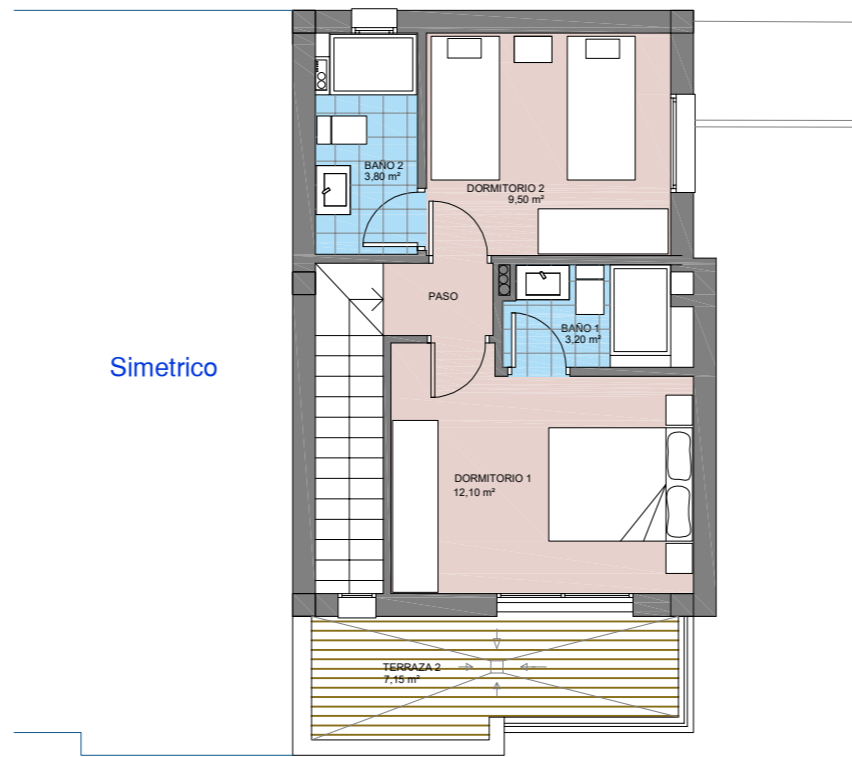

PLANTA PRIMERA

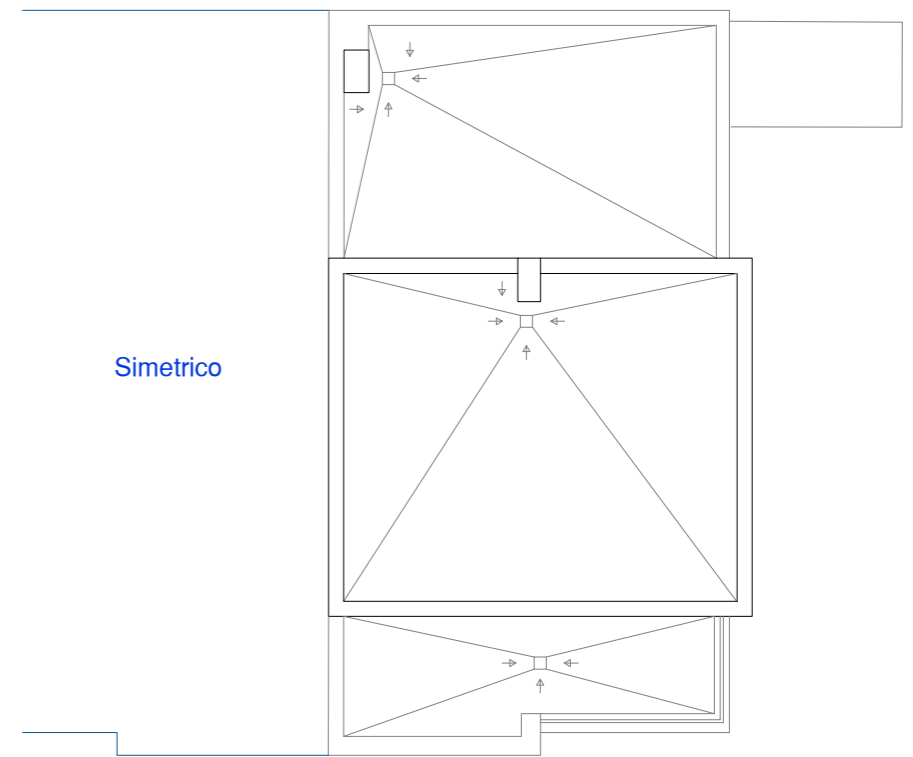

PLANTA CUBIERTA

Simetrico

Simetrico

Simetrico

DISTRIBUCIÓN VIVIENDA

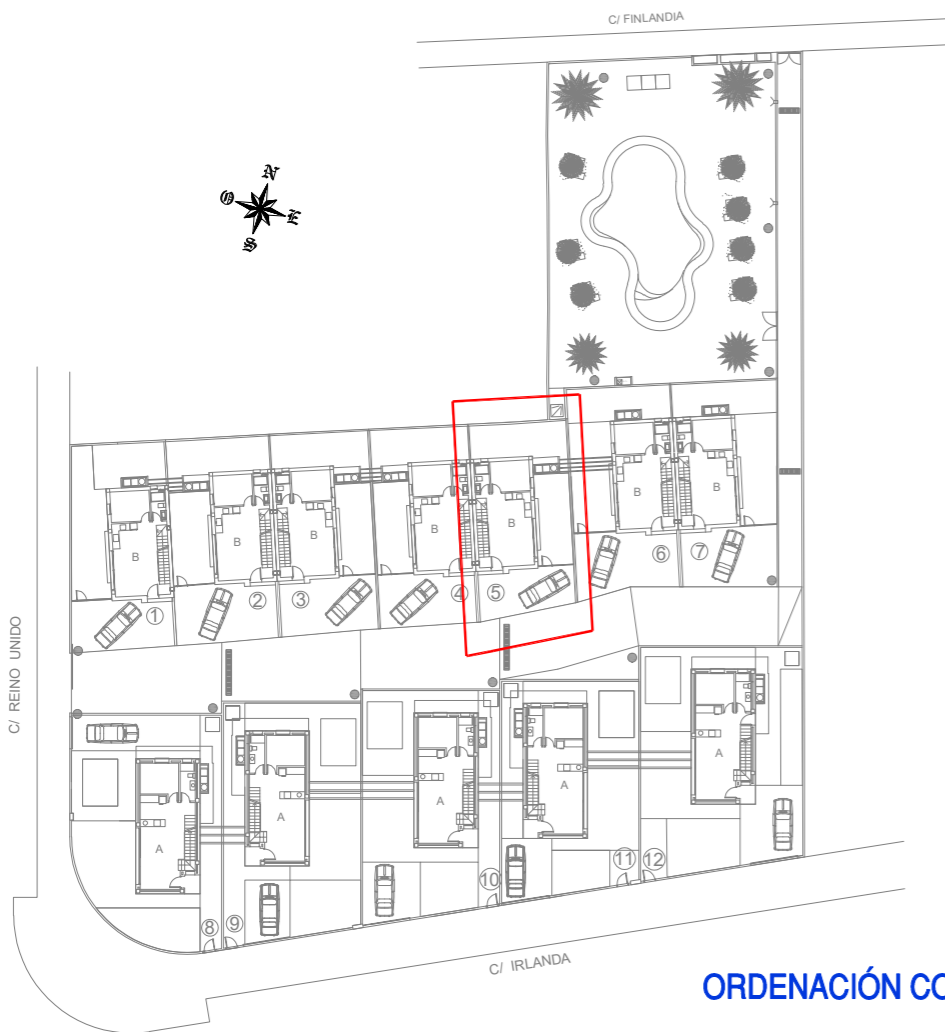

ORDENACIÓN CONJUNTO

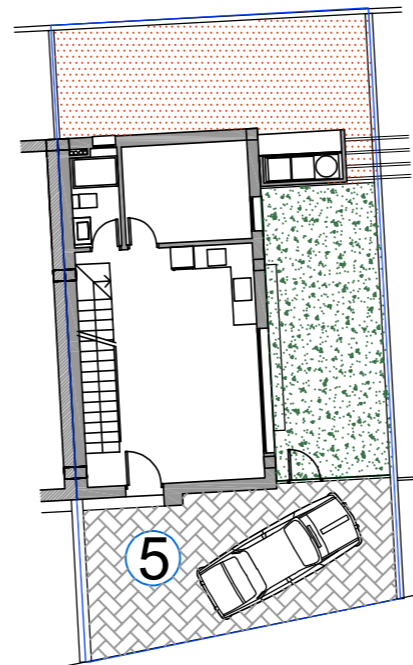

PLANO DE PARCELA

		C/ Clavel Florentino, 134 03203 EL CHE (Alicante) Telf.: 96 541 03 78 www.asagrupo.com	
		CUADRO DE SUPERFICIES Manzanera M17	
PARCELA 5 AGRUPADA		TOTAL SUPERFICIE PARCELA 5	
		136,70m²	
VIVIENDA 4			
PLANTA BAJA	VIVIENDA	54,65m ²	54,65m ²
PLANTA ALTA	VIVIENDA	43,90m ²	43,90m ²
TOTAL SUPERFICIE VIVIENDA		98,55m²	
RESTO PARCELA - JARDIN - APARCAMIENTO		82,05m²	

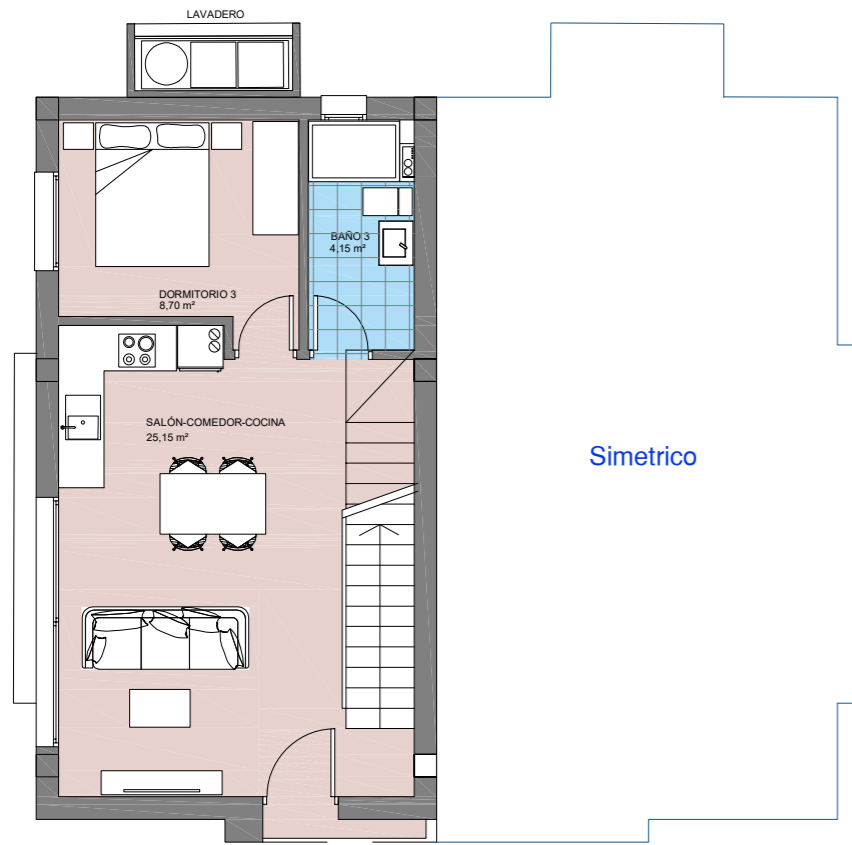

Simetrico

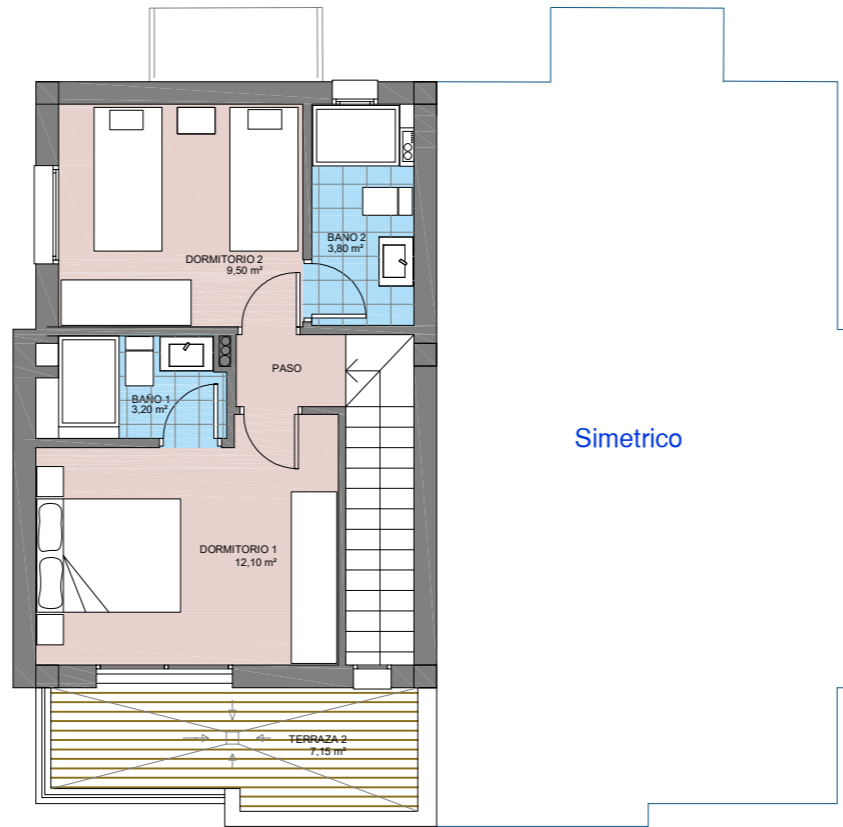

Simetrico

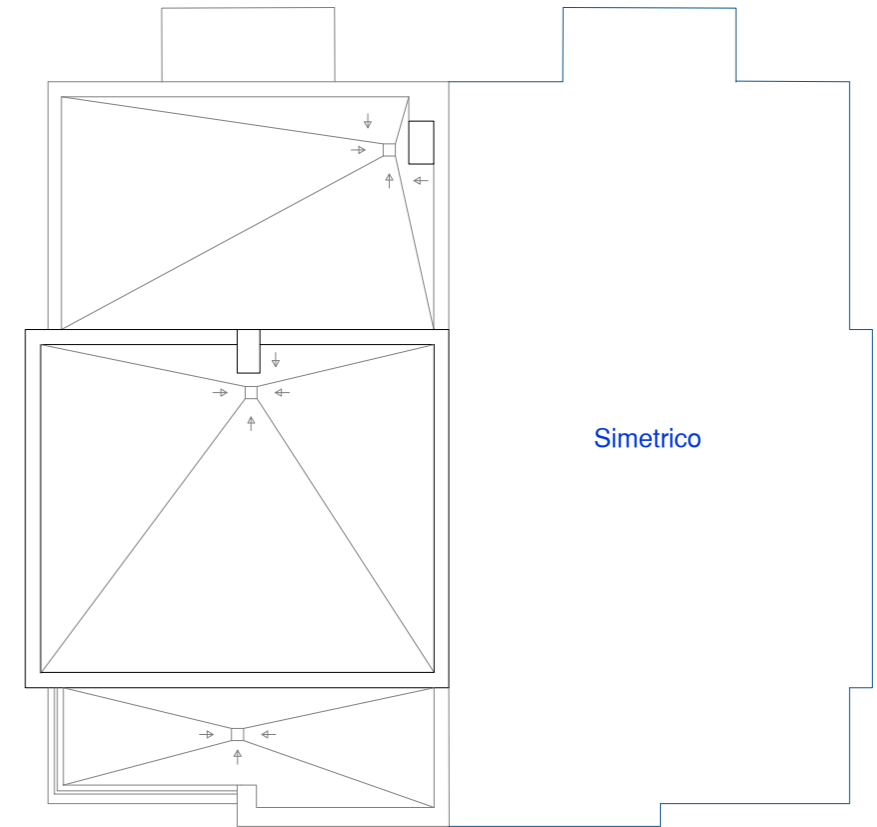

Simetrico

PLANTA BAJA

PLANTA PRIMERA

PLANTA CUBIERTA

DISTRIBUCIÓN VIVIENDA

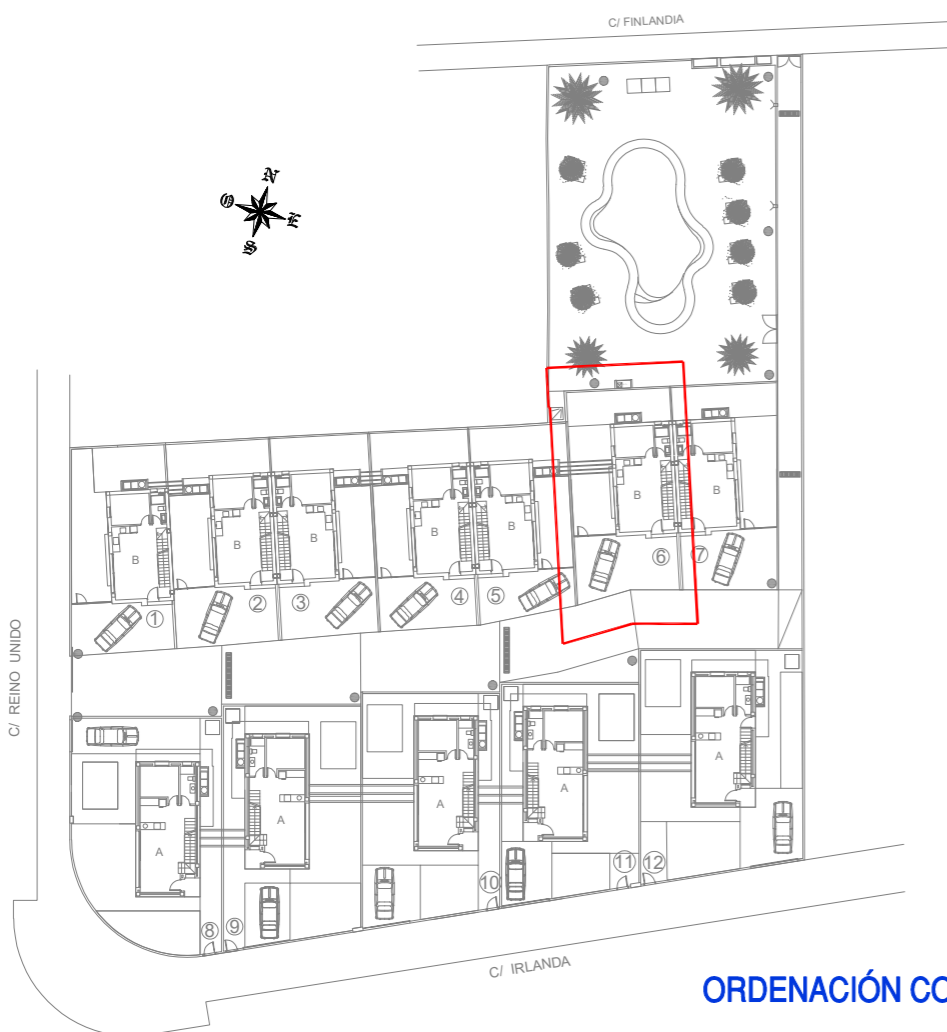

ORDENACIÓN CONJUNTO

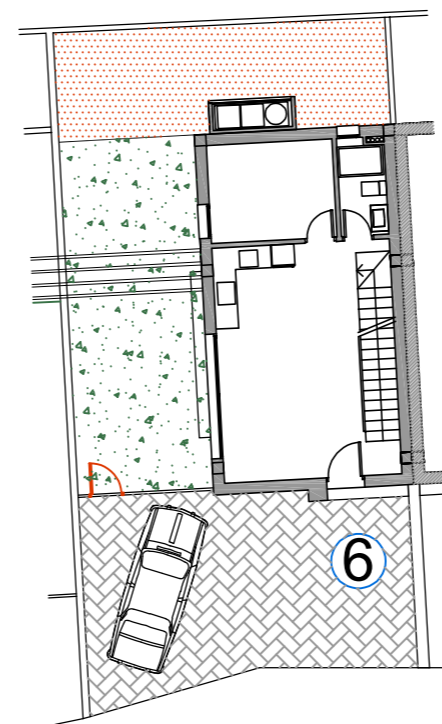

PLANO DE PARCELA

		C/ Clavel Florentino, 134 03203 EL CHE (Alicante) Telf: 96 541 03 78 www.asagrupo.com	
		CUADRO DE SUPERFICIES Manzana M17	
PARCELA 6 AGRUPADA		TOTAL SUPERFICIE PARCELA 6	
		155,75m²	
VIVIENDA 4			
PLANTA BAJA	VIVIENDA	54,65m ²	54,65m ²
PLANTA ALTA	VIVIENDA	43,90m ²	
TOTAL SUPERFICIE VIVIENDA		98,55m²	
RESTO PARCELA - JARDIN - APARCAMIENTO		101,10m²	

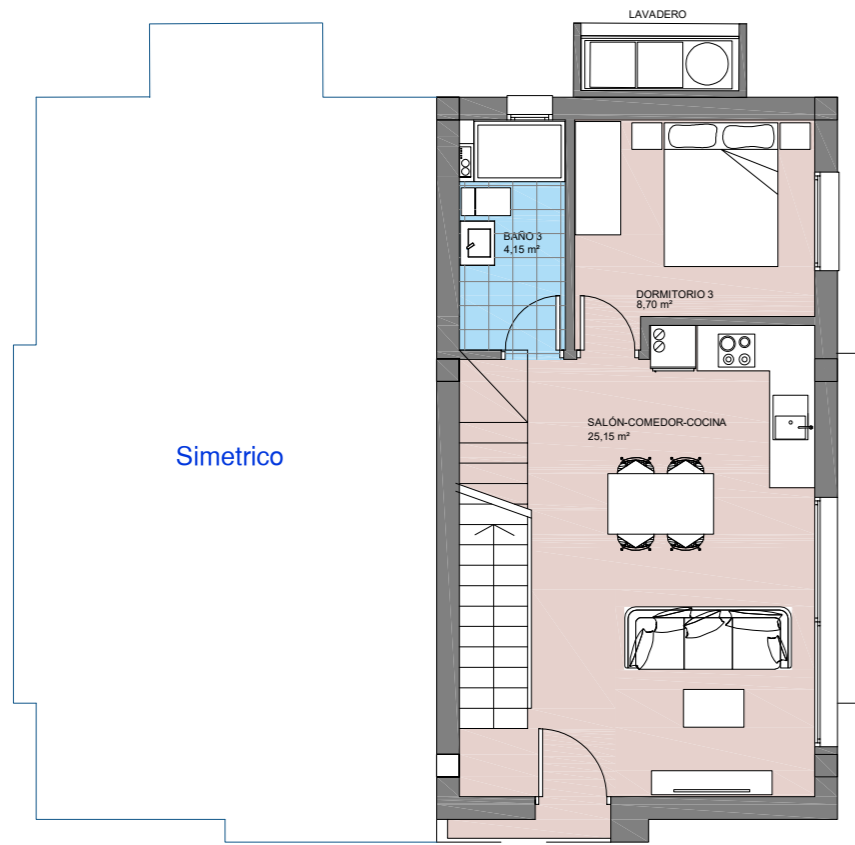

Simetrico

PLANTA BAJA

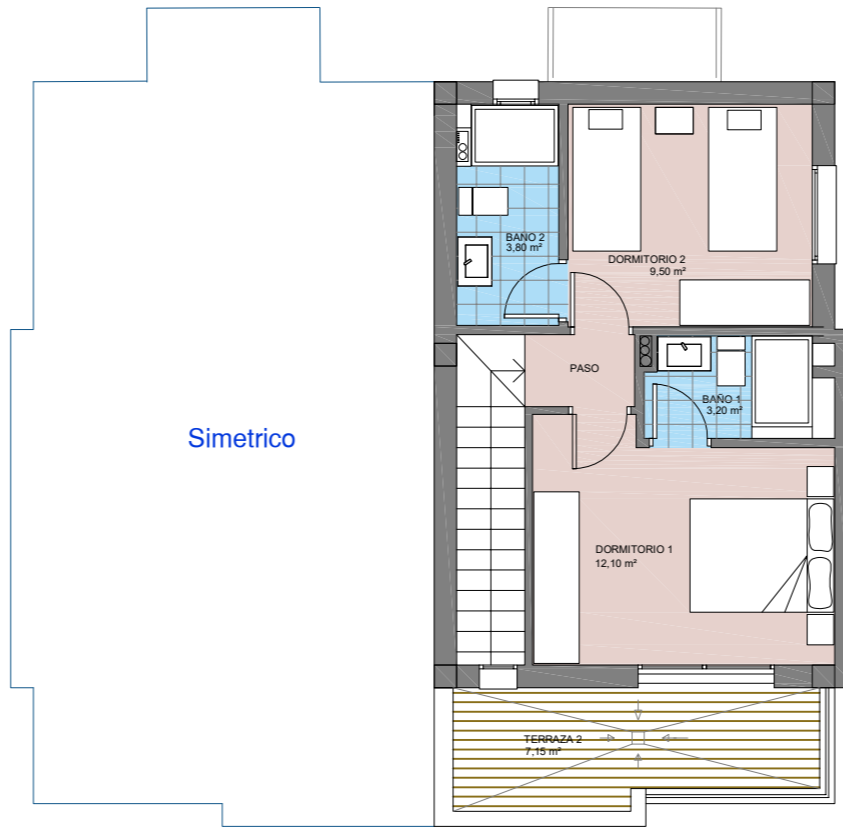

Simetrico

PLANTA PRIMERA

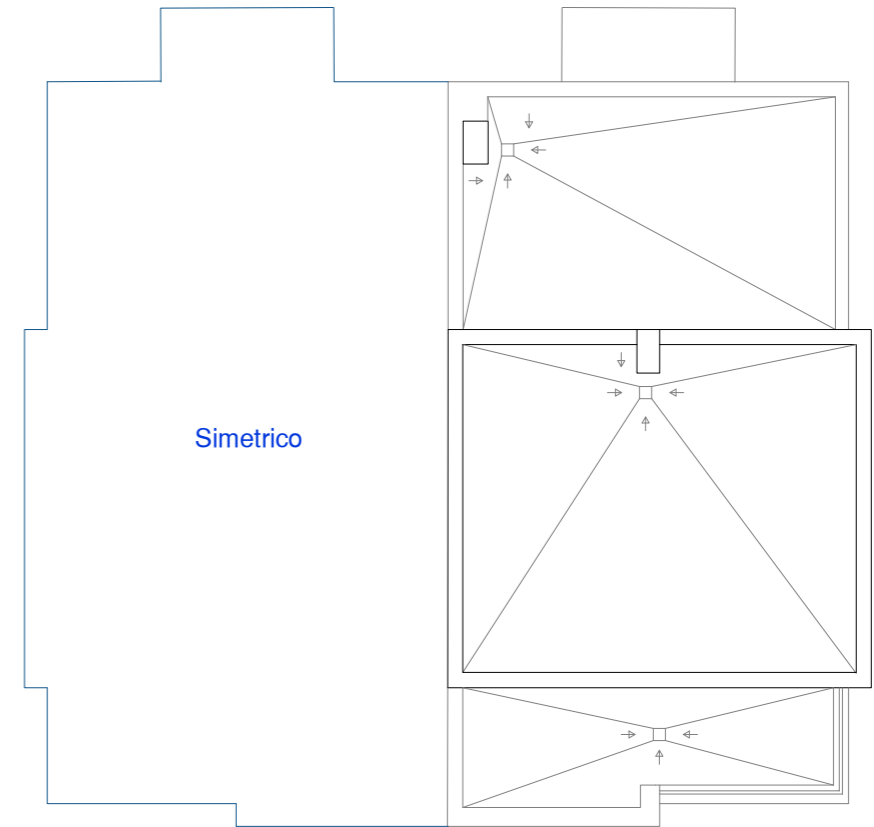

Simetrico

PLANTA CUBIERTA



DISTRIBUCIÓN VIVIENDA

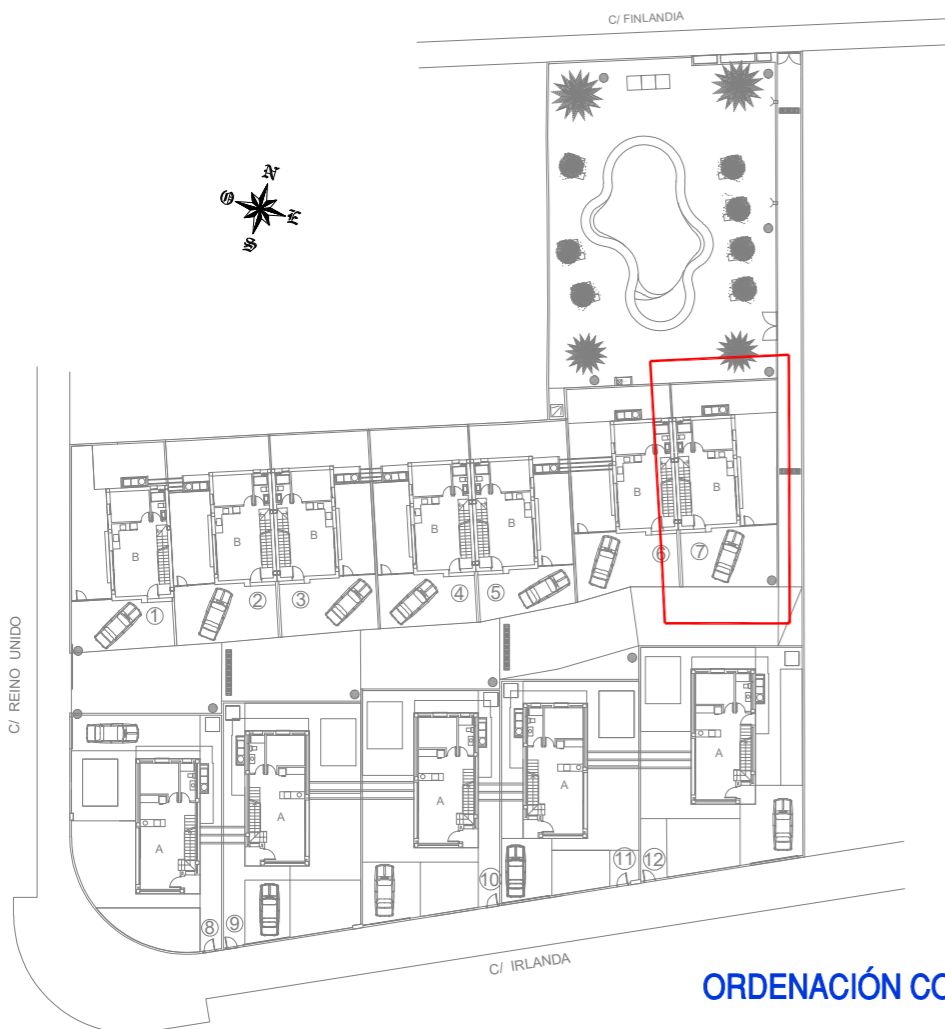

ORDENACIÓN CONJUNTO

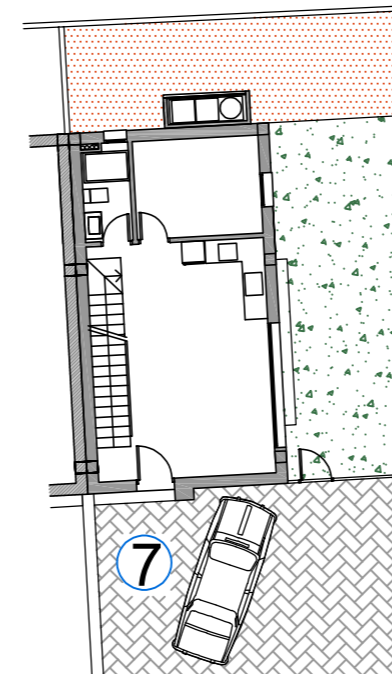

PLANO DE PARCELA

		C/ Clavel Florentino, 134 03203 ELICHE (Alicante) Telf.: 96 541 03 78 www.asagrupo.com	
		CUADRO DE SUPERFICIES Manzana M17	
PARCELA 7 AGRUPADA		TOTAL SUPERFICIE PARCELA 7	
		151,75m2	
VIVIENDA 4		TOTAL SUPERFICIE VIVIENDA	
PLANTA BAJA	VIVIENDA	54,65m2	54,65m2
PLANTA ALTA	VIVIENDA	43,90m2	
		43,90m2	
RESTO PARCELA - JARDIN - APARCAMIENTO		97,10m2	